

# FOR SALE

## 28,030 SF Industrial Building

2185 Park Place  
Minden, NV 89423



### Offering Highlights

- \$2,600,000 Asking Price (+/- \$92 per square foot)
- 28,030 total Square feet
- 1,200 Amps 480v 3 - phase power
- Building can be demised to 3 tenant spaces
- 4 Grade level loading doors
- Situated on 2 acres of land
- Great opportunity for Investor or Owner User



[www.commercialrealestatenv.com](http://www.commercialrealestatenv.com)

The information contained herein has been provided by the owner or other sources deemed reliable. The Broker does not guarantee the accuracy of this information. All information should be verified by the recipient prior to the purchase, lease or exchange.

Contact:  
Chad Coons, CCIM  
(775) 720-2115 cell  
(775) 782-3434 office  
2288 Main Street  
Genoa, NV 89411  
chadcoons@gmail.com

# 2185 Park Place (Minden, NV)

## Property Details

### Building Specifications

- ◆ 28,030 total square feet
- ◆ 1,200 Amps 480v 3 phase
- ◆ 4 Grade level doors, 10x14, 10x12, 15x13, 16x15
- ◆ Full fire suppression system
- ◆ Thicker slab areas for heavy precision equipment
- ◆ 9 total skylights
- ◆ 6 total restrooms
- ◆ Swamp coolers for cooling
- ◆ Reznor heating in warehouse and full HVAC in offices.
- ◆ Approximately 4,700 SF office space
- ◆ Building was added on making 3 easily demised spaces for multi tenant building. Spaces would be approx. 9,992 SF, 5,225 SF & 12,812 SF
- ◆ +/- 53 parking spaces including ADA





# 2185 Park Place (Minden, NV)

## Location

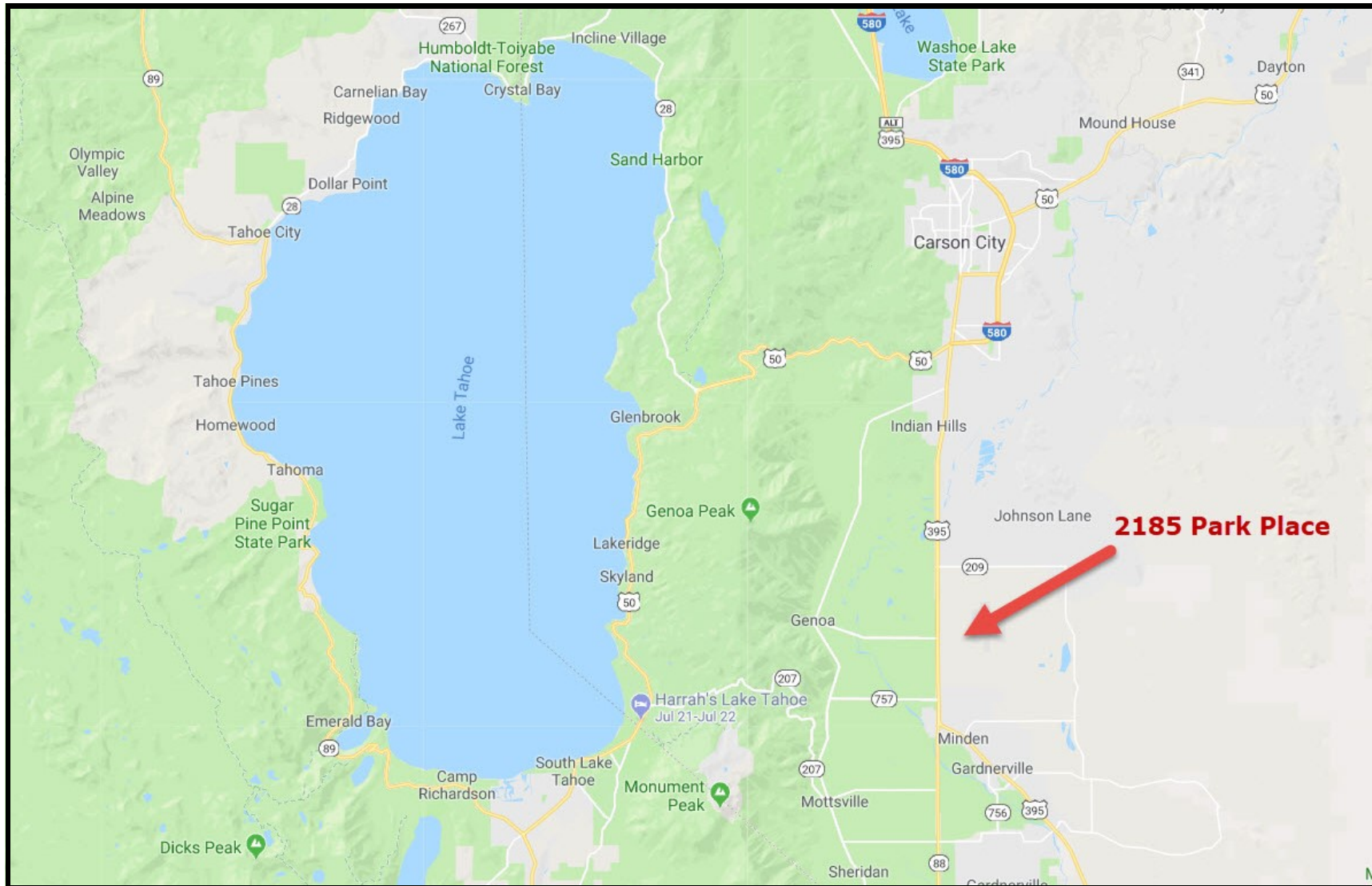

# 2185 Park Place (Minden, NV) Parcel Summary

## Parcel Map

Address	Parcel #	Acres	Land SF	Zoning
2185 Park Place	1320-08-410-016	2	+/- 87,120	LI

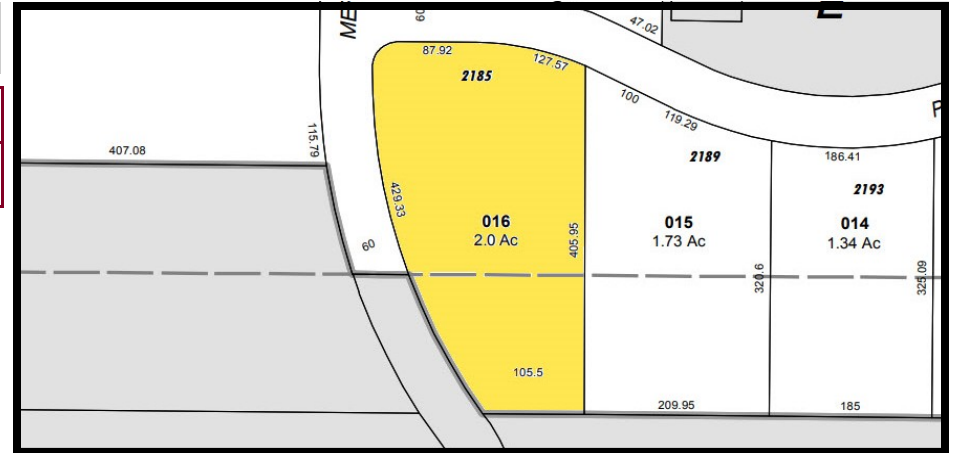

## Site Map





# 2185 Park Place (Minden, NV) Floor Plans

## Assessor Sketch

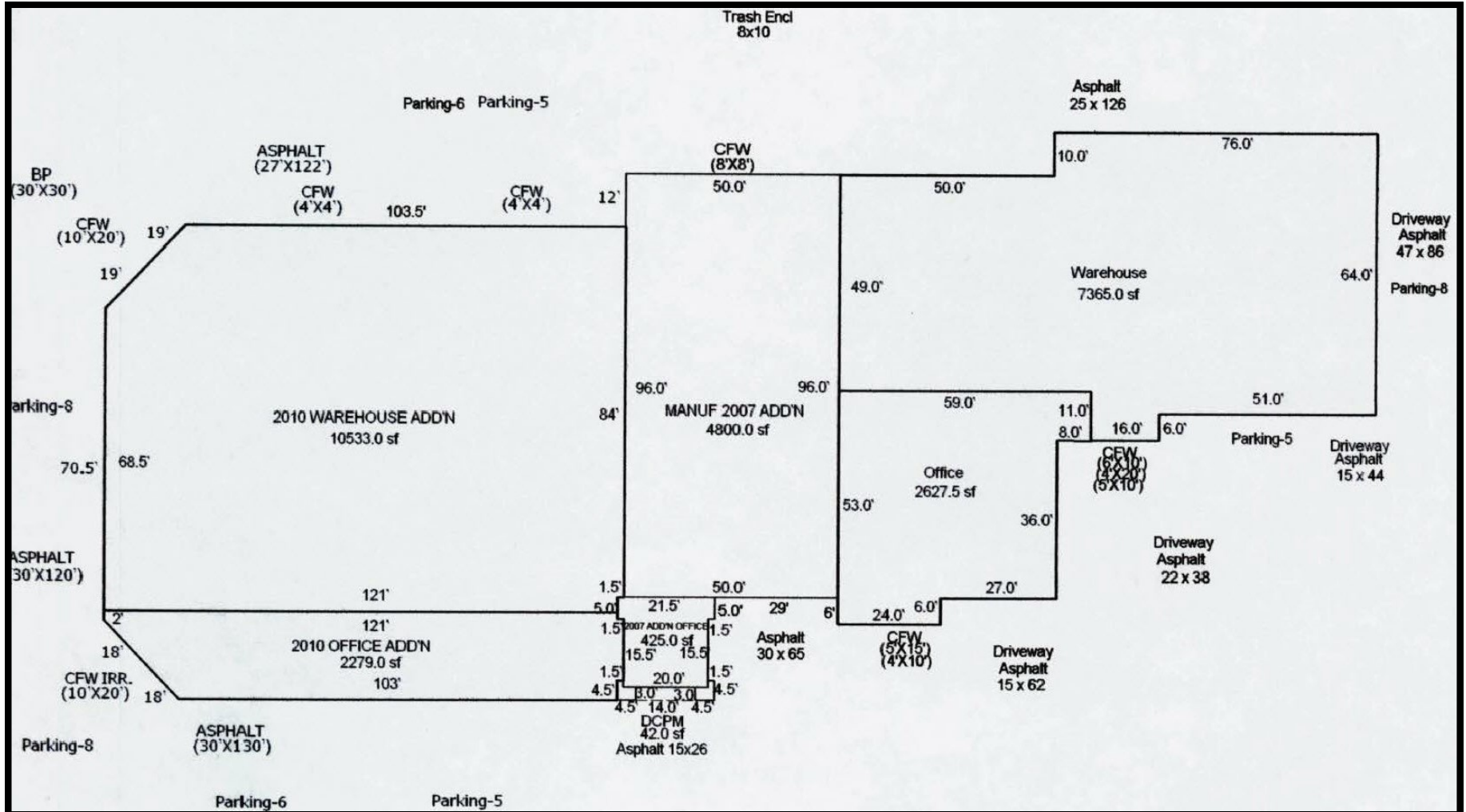

# 2185 Park Place (Minden, NV)

## Pictures



**For Property Information or Site Visits Contact:**

**Chad Coons, CCIM**  
(775) 720-2115 cell  
(775) 782-3434 office  
2288 Main Street  
Genoa, NV 89411  
chadcoons@gmail.com  
[www.commercialrealestatenv.com](http://www.commercialrealestatenv.com)

